

MGH Hidrolik Giyotin

Hydraulic swing-beam Shears



GENEL ÖZELLİKLER / DESIGN AND OPERATING FEATURES

- Statik ve dinamik rijitliği sağlanmış, kaynaklı sac konstrüksiyon gövde
- Rulmanlı yataklarda mafsal sistemi ile çalışan üst çene
- Kolay ayarlanabilen sentil sistemi
- Arka dayama mesafesinden uzun sacları kesmeye elverişli, kalkmalı tip arka dayama sistemi
- Yağ tankı üzerine yerleştirilmiş, kompakt ve az bakım gerektiren hidrolik sistem ünitesi
- Kolay servis edilebilir, seri bağlanmış hidrolik silindirlere
- Kesme anında sacın kaymasını önleyen hidrolik baskı sistemi
- Aşırı basınç yükselmesine karşı hidrolik emniyet sistemi
- Alt çenede hassas bıçak ayar sistemi
- Kısa boy kesimlerde vuruş sayısını arttırmak üzere ayarlanabilir kesme-strok uzunluğu
- Maksimum 250 mm genişliğinde devamlı şerit kesmeye elverişli ayak boğaz derinliği
- Welded all-steel frame providing maximum rigidity and cutting accuracy
- Swinging top beam working on high precision and self-aligning roller bearings
- Rapid blade gap adjustment mechanism
- Swing-up backgauge system for shearing longer pieces than maximum backgauge range
- Backgauge retract function
- Compact, low-maintenance hydraulic unit located above oil tank
- Easily servicable hydraulic cylinders in series connection
- Hydraulic holddown system
- Hydraulic overload protection
- Fine adjustment of blades from lower beam
- Adjustable stroke length to increase number of strokes on shorter cuts
- 250 mm side frame throat gaps allowing continuous strip slitting





STANDART EKİPMANLAR / STANDARD EQUIPMENT

- Aşınma direnci ve tokluğu yüksek bıçaklar.

Üst bıçak : Çift ağızlı
Alt bıçak : Dört ağızlı

- 0.1 mm hassasiyetinde 1000 mm uzunluğunda bilyalı milli motorlu arka dayama
- Arka dayama dijital kontrol ünitesi
- Dijital vuruş sayacı
- Tek ve seri kesmeye elverişli ayak pedal sistemi
- Cetveli, stoperli ve T-kanallı 1000 mm uzunluğunda yan gönye
- 1000 mm uzunluğunda ön destek kolları
- Bilya sürücülü ve kanallı sac konstrüksiyon tabla
- Acil stop butonları
- Bıçak aydınlatması ve gölge teli
- Koruyucu ön ve yan muhafazalar

- Shear blades made from tough and wear-resistant alloyed material

Top blade : two cutting edges
Bottom blade : four cutting edges

- 1000 mm power backgauge with ballscrew spindles to 0.1 mm precision
- Backgauge digital readout control
- Digital stroke counter
- Foot pedal control for single and repetitive cutting cycles
- 1000 mm squaring arm with scale, T-slot and flip-stop
- Front support arms in 1000 mm length
- Work table with filler plates, ball transfers and hand slots
- Emergency stop buttons
- Shadow line facility with fluorescent lighting
- "See-through" finger guard and side throat guards



MGH Hidrolik Giyotin

Hydraulic swing-beam Shears



Delem DAC 310



Motorlu sentil ayar sistemi
Power blade gap adjustment

ÖZEL İSTEK EKİPMANLARI / OPTIONAL EQUIPMENT



A tipi pnömatik arka destek sistemi
Type A pneumatic rear support system

- Motorlu ve dijital kontrollü sentil ayar sistemi
- İnce saclar için pnömatik arka destek sistemleri
- Çalışma zamanı sayacı
- Standart harici uzunlukta yan gönye ve ön destek kolları
- Cetveli, stoperli ve T-kanallı ön destek kolları
- Standart harici ayak boğaz derinliği
- Açılı gönye
- 1000 mm açılabilir, emniyet sviçli ön muhafaza
- Baskı silindir tamponları
- Arka emniyet muhafazası
- Avrupa Birliği CE normlarına uygunluk
- Power blade gap adjustment with digital readout control
- Pneumatic rear support systems for thin sheets
- Worktime counter
- Squaring arm and front arm length other than standard
- T-slotted front support arms with scale and flip-stop
- Throat gap deeper than standard
- Angle gauge
- 1000 mm lift-up front finger guard with electrically interlocked safety switch
- Holddown pads
- Rear safety guarding
- Conformity to European Community CE norms

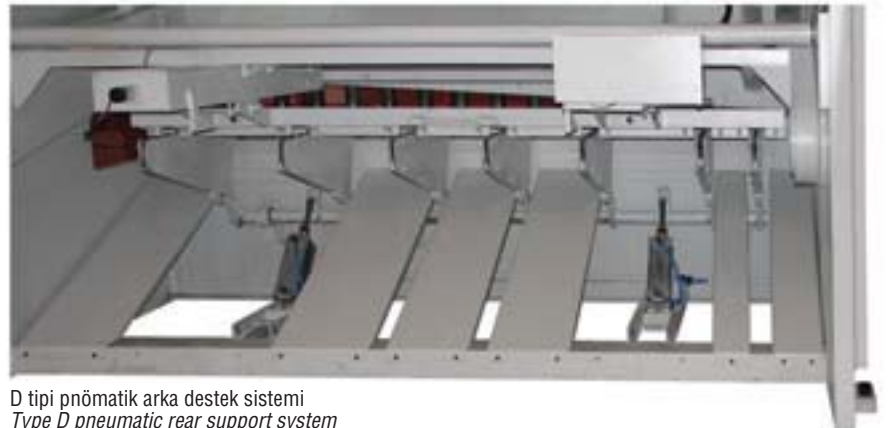

D tipi pnömatik arka destek sistemi
Type D pneumatic rear support system



TEKNİK ÖZELLİKLER / TECHNICAL DATA

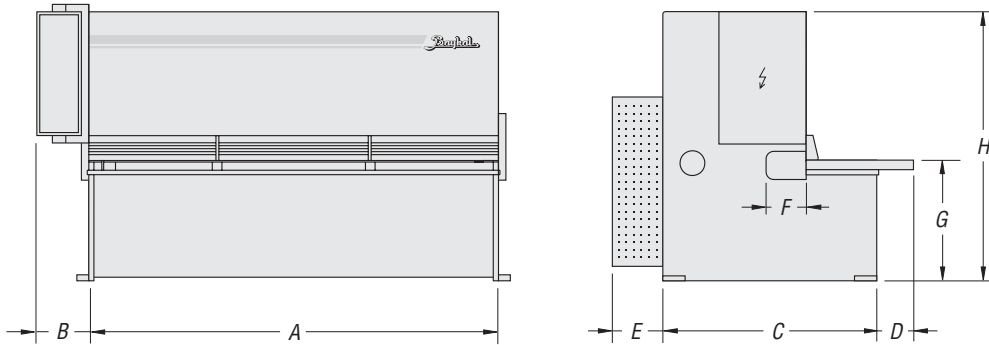

TIPLER TYPES	Kesme Kapasitesi Shearing capacity		Kesme boyu Cutting length	Kesme açısı Rake angle	Motor gücü Motor power	Baskı sayısı Number of holdowns	Strok sayısı Strokes per minute	Yağ tankı kapasitesi Capacity of oil tank	Arka dayama açıklığı Back gauge range	Arka dayama motoru Back gauge motor	Takribi ağırlık Weight	A	B	C	D	E	G	H	F
	≤450 N/mm ²	≤700 N/mm ²																	
	mm	mm	mm	derece deg.	kW	adet pcs.	adet/dak. cuts/min.	Lt	mm	kW	kg	mm	mm	mm	mm	mm	mm	mm	mm
MGH 3100 x 6	6	4	3060	1.5°	11	17	18	170	1000	0.37	7000	3340	430	1600	500	1000	800	1825	250
MGH 3100 x 10	10	6	3060	2°	22	17	12	170	1000	0.37	9200	3420	430	1775	500	1000	800	1850	250
MGH 3100 x 13	13	8	3060	2.4°	30	17	12	220	1000	0.37	11500	3450	430	1985	500	1000	900	2060	250
MGH 3100 x 16	16	10	3060	2.7°	30	17	7	220	1000	0.55	15500	3410	430	2150	400	1000	900	2230	250
MGH 3100 x 20	20	13	3060	3°	37	18	7	280	1000	0.55	19600	3470	430	2140	400	1000	900	2440	250
MGH 4100 x 10	10	6	4060	2°	22	23	10	170	1000	0.37	13000	4370	430	1975	400	1000	800	1910	250
MGH 4100 x 13	13	8	4060	2.2°	30	23	8	220	1000	0.37	16100	4400	430	1975	400	1000	900	2160	250

Dizayn ve teknik özellikler önceden haber vermeden değiştirilebilir. / Design and specifications are subject to change without notice.